



INSTALLATION MANUAL
Response Series DSP Amplifiers
EA-RSP-2D-200
EA-RSP-8D-100
EA-RSP-12D-100
EA-RSP-16D-100



REAL. LIFE. SOUND.

WELCOME TO EPISODE

The Response Series DSP amplifiers deliver high performance and reliable and robust amplification in a compact form factor—providing the perfect audio distribution solution for any size home.

SUPPORTED MODELS

EA-RSP-2D-200
EA-RSP-8D-100
EA-RSP-12D-100
EA-RSP-16D-100

PACKAGE CONTENTS

- Amplifier
- IEC power cable (1)
- Feet (4)
- Rack-mount ears (2) and screws (10)
- Phoenix-style speaker connectors (8-, 12-, and 16-channel models only)

FEATURES

- All-in-one design includes pre-amplification, digital signal processing, matrix switching (8-, 12-, and 16-channel models only) and amplification, in one chassis.
- 8-, 12-, and 16-channel models send multiple audio sources to as many as 4, 6, or 8 stereo audio zones, for reliable multi-room audio distribution.
- Cool-running Class D amplification: 8-, 12-, and 16-channel models provide 100WPC @4 ohm and the 2-channel model provides 200 WPC @4 ohm.
- Bridgeable outputs provide double the amplification for areas that require more power.
- Speaker outputs can be set to stereo or mono operation.
- Subwoofer RCA outputs included for 2.1 audio in every zone.
- Source loop outputs allow multiple amplifiers to be chained together for larger audio installations.
- Independent volume control with real-time volume and mute status for connected user interfaces.
- Independent input gain for each source, with optional anti-clipping feature, providing consistent levels when switching between sources.
- Each output provides powerful DSP capabilities including a 10-band parametric EQ, tone controls, high- and low- pass filters, audio delay, and a limiter.
- Wide assortment of DSP presets including genre-based, custom, and Episode speaker presets.
- Ethernet controlled, with a browser user interface, enabling easy setup of all system parameters.
- OvrC-enabled for remote management, monitoring, and alerts.
- IR input and output for optional infrared remote control.
- Standby mode saves energy by turning off amplifier channels when not in use.
- Voltage trigger input and output enable power control of the amplifier from devices with a voltage trigger output.
- Heat dissipation: Two fans (8-, 12-, and 16-channel models) or passive (2-channel model).

IMPORTANT SAFETY INSTRUCTIONS / CONSIGNES DE SÉCURITÉ IMPORTANTES

Read the safety instructions before using this product.

Lisez les consignes de sécurité avant d'utiliser ce produit.

1. Read these instructions. / Lisez ces instructions.
2. Keep these instructions. / Conservez ces instructions.
3. Heed all warnings. / Respectez tous les avertissements.
4. Follow all instructions. / Suivez toutes les instructions.
5. Do not use this apparatus near water. / Ne pas utiliser cet appareil près de l'eau.
6. Clean only with dry cloth. / Nettoyez-le uniquement avec un chiffon sec.
7. Do not block any ventilation openings. Install in accordance with the manufacturer's instructions. / Ne pas bloquer les ouvertures de ventilation. Installer conformément aux instructions du fabricant.
8. Do not install near any heat sources such as radiators, heat registers, stoves, or other apparatus (including amplifiers) that produce heat.



Ne pas installer près de sources de chaleur telles que des radiateurs, registres de chaleur, poêles, ou autres appareils (incluant les amplificateurs) qui produisent de la chaleur.

- 9.** Do not defeat the safety purpose of the polarized or grounding-type plug. A polarized plug has two blades with one wider than the other. A grounding type plug has two blades and a third grounding prong. The wide blade or the third prong is provided for your safety. If the provided plug does not fit into your outlet, consult an electrician for replacement of the obsolete outlet.

Ne pas contourner le dispositif de sécurité de la fiche polarisée ou de mise à la terre. Une fiche polarisée possède deux lames dont une plus large que l'autre. Une fiche de terre a deux lames et une troisième broche de terre. La lame large ou la troisième broche est fournie pour votre sécurité. Si la fiche fournie ne s'adapte pas à votre prise, consultez un électricien pour le remplacement de la prise obsolète.

- 10.** Protect the power cord from being walked on or pinched particularly at plugs, convenience receptacles, and the point where they exit from the apparatus.
Protégez le cordon d'alimentation ne soit piétiné ou pincé, en particulier au niveau des fiches, des prises et au point où il sort de l'appareil.

- 11.** Only use attachments/accessories specified by the manufacturer.
Utilisez uniquement des fixations / accessoires spécifiés par le fabricant.

- 12.** Use only with the cart, stand, tripod, bracket, or table specified by the manufacturer, or sold with the apparatus. When a cart is used, use caution when moving the cart/apparatus combination to avoid injury from tip-over.
Utilisez uniquement avec le chariot, le socle, le trépied, le support ou la table spécifiés par le fabricant ou vendu avec l'appareil. Lorsque vous utilisez un chariot, soyez prudent lorsque vous déplacez l'ensemble chariot / appareil pour éviter des blessures dues au renversement.



- 13.** Unplug this apparatus during lightning storms or when unused for long periods of time.
Débranchez cet appareil pendant les orages ou lorsqu'il n'est pas utilisé pendant de longues périodes de temps.
- 14.** Refer all servicing to qualified service personnel. Servicing is required when the apparatus has been damaged in any way, such as power-supply cord or plug is damaged, liquid has been spilled or objects have fallen into the apparatus, the apparatus has been exposed to rain or moisture, does not operate normally, or has been dropped.
Confiez toutes les réparations à un personnel qualifié. Une réparation est nécessaire lorsque l'appareil a été endommagé de quelque façon que ce soit le cordon d'alimentation ou la fiche est endommagé, du liquide a été renversé ou si des objets sont tombés dans l'appareil, l'appareil a été exposé à la pluie ou à l'humidité, ne fonctionne pas normalement, ou s'il est tombé.

- 15.** This equipment uses AC power which can be subjected to electrical surges, typically lightning transients which are very destructive to customer terminal equipment connected to AC power sources. The warranty for this equipment does not cover damage caused by electrical surge or lightning transients. To reduce the risk of this equipment becoming damaged it is suggested that the customer consider installing a surge arrestor.
Cet équipement utilise la puissance AC qui peuvent être soumis à des surtensions électriques, la foudre généralement transitoires qui sont très destructives envers les équipements terminaux connectés à des sources d'alimentation CA. La garantie de cet appareil ne couvre pas les dommages causés par les surtensions électriques ou transitoires de foudre. Pour réduire le risque de cet équipement devient endommagé, il est suggéré que le client envisager l'installation d'un limiteur de surtension.

- 16.** To completely disconnect unit power from the AC mains, remove the power cord from the appliance coupler and/or turn off the circuit breaker. To reconnect power, turn on the circuit breaker following all safety instructions and guidelines. The circuit breaker shall remain readily accessible.
Pour débrancher complètement l'alimentation secteur du réseau secteur, retirez le cordon d'alimentation du coupleur de l'appareil et / ou éteignez le disjoncteur. Pour reconnecter l'alimentation, allumez le disjoncteur en suivant toutes les consignes et consignes de sécurité. Le disjoncteur doit être facilement accessible.

- 17.** This product relies on the buildings installation for short-circuit (overcurrent) protection. Ensure that the protective device is rated not greater than: 20A.
Ce produit repose sur l'installation des bâtiments pour les courts-circuits (surtension) de protection. Assurez-vous que le dispositif de protection est assignée ne dépassant pas: 20A.

- 18.** Never push objects of any kind into this product through cabinet slots as they may touch dangerous voltage points or short out parts that could result in fire or electric shock.
N'introduisez jamais d'objets d'aucune sorte dans ce produit à travers les fentes du boîtier car ils pourraient toucher des points de tension dangereux ou court-circuiter des pièces qui pourraient entraîner un incendie ou un choc électrique.

- 19.** This product can interfere with electrical equipment such as tape recorders, TV sets, radios, computers and microwave ovens if placed in close proximity.
Ce produit peut interférer avec des appareils électriques tels que les magnétophones, téléviseurs, radios, ordinateurs et fours à micro-ondes si placés à proximité.

Warnings



This lightning flash with an arrow head symbol, within an equilateral triangle, is intended to alert the user to the presence of un-insulated “dangerous voltage” within the product’s enclosure that may be of sufficient magnitude to constitute a risk of electric shock to the person.

Cette flèche en forme d’éclair dans un triangle équilatéral attire l’attention de l’utilisateur sur la présence d’une « tension dangereuse » non isolée à l’intérieur du châssis de l’appareil susceptible de présenter un risque d’électrocution.



Caution: To reduce the risk of electric shock, do not remove cover (or back). No user serviceable parts inside. Refer servicing to qualified service personnel.

Attention: Pour réduire le risque de choc électrique, ne pas retirer le couvercle (ou l’arrière). Aucune pièce réparable par l’utilisateur. Confiez l’entretien à un personnel qualifié.



The exclamation point within the triangle is a warning sign alerting you of important instructions accompanying the product.

Le point d’exclamation dans un triangle est un signe d’avertissement vous signale des instructions importantes accompagnant le produit.

See marking on bottom / back of product

Voir le marquage sur les bas / dos du produit



Warning! To reduce the risk of electrical shock, do not expose this apparatus to rain or moisture

AVERTISSEMENT ! Pour réduire le risque de choc électrique, n’exposez pas cet appareil à la pluie ou à l’humidité.



AC voltage: This symbol indicates that the rated voltage marked with the symbol is AC voltage.

CAUTION: FOR CONTINUED PROTECTION AGAINST THE RISK OF FIRE REPLACE ONLY WITH SAME TYPE OF FUSE.

Warning: To reduce the risk of electric shock, do not remove cover (or back), no user-serviceable parts inside. Refer servicing to qualified service personnel.

Avertissement : pour réduire le risque d’électrocution, ne retirez pas le couvercle (ou l’arrière) de l’appareil. Les pièces se trouvant à l’intérieur ne sont pas réparables par l’utilisateur. Adressez-vous à un technicien qualifié.

Save these instructions / Conservez ces instructions

Compliance of this equipment is confirmed by the following label that is placed on the equipment: Conformité de cet appareil est confirmé par le symbole suivant qui est placé sur l’équipement:



REGULATORY INFORMATION

United States—FCC

Changes or modifications not expressly approved by the party responsible for compliance could void the user's authority to operate the equipment.

Note: This equipment has been tested and found to comply with the limits for a Class B digital device, pursuant to part 15 of the FCC Rules. These limits are designed to provide reasonable protection against harmful interference in a residential installation. This equipment generates, uses and can radiate radio frequency energy and, if not installed and used in accordance with the instructions, may cause harmful interference to radio communications. However, there is no guarantee that interference will not occur in a particular installation. If this equipment does cause harmful interference to radio or television reception, which can be determined by turning the equipment off and on, the user is encouraged to try to correct the interference by one or more of the following measures:

- Reorient or relocate the receiving antenna.
- Increase the separation between the equipment and receiver.
- Connect the equipment into an outlet on a circuit different from that to which the receiver is connected.
- Consult the dealer or an experienced radio/TV technician for help.

To satisfy FCC / IC RF exposure requirements, a separation distance of 20 cm or more should be maintained between the antenna of this device and persons during device operation.

To ensure compliance, operations at closer than this distance is not recommended.

Les antennes installées doivent être situées de façon à ce que la population ne puisse y être exposée à une distance de moins de 20 cm. Installer les antennes de façon à ce que le personnel ne puisse approcher à 20 cm ou moins de la position centrale de l'antenne.

La FCC des États-Unis stipule que cet appareil doit être en tout temps éloigné d'au moins 20 cm des personnes pendant son fonctionnement.

Limited by local law regulations, version for North America does not have region selection option.

Canada

This device contains licence-exempt transmitter(s)/receiver(s) that comply with Innovation, Science and Economic Development Canada's licence-exempt RSS(s). Operation is subject to the following two conditions:

- (1) This device may not cause interference.
- (2) This device must accept any interference, including interference that may cause undesired operation of the device.

L'émetteur/récepteur exempt de licence contenu dans le présent appareil est conforme aux CNR d'Innovation, Sciences et Développement économique Canada applicables aux appareils radio exempts de licence. L'exploitation est autorisée aux deux conditions suivantes :

- 1) L'appareil ne doit pas produire de brouillage;
- 2) L'appareil doit accepter tout brouillage radioélectrique subi, même si le brouillage est susceptible d'en compromettre le fonctionnement.

Canada Warning Statement: CAN ICES-3 (B)/NMB-3(B)

This product meets the applicable Innovation, Science and Economic Development Canada technical specifications.

Ce produit répond aux spécifications techniques applicables à l'innovation, Science et Développement économique Canada.

Recycling



Correct Disposal of Waste Electrical and Electronic Equipment (WEEE) by User in Private Households in the EU.

This symbol on the product or accessories indicates that they must not be disposed of with your household wastes throughout the EU. To prevent possible harm to the environment or human health from uncontrolled waste disposal, recycle it responsibly to promote the sustainable reuse of material resources. Instead it is your responsibility to dispose of your waste equipment by handing it over to a designated WEEE collection point for recycling. The separate collection and recycling of your waste equipment will help conserve natural resources and ensure that it is recycled in a manner that protects human health and the environment.

For more specific information about where you can take your equipment for recycling please contact your local city/council office, your local waste disposal service or the outlet where you purchased your product.

Élimination correcte des déchets d'équipements électriques et électroniques (directive DEEE) par l'utilisateur domestique au sein de l'UE. Ce symbole indique qu'au sein de l'UE, le produit ou les accessoires qui en sont porteurs ne doivent pas être jetés avec vos ordures ménagères. Pour éviter tout danger pour l'environnement ou pour la santé des êtres humains dû à une élimination incontrôlée des déchets, veuillez recycler ces produits ou accessoires de manière responsable, dans le but de promouvoir la réutilisation des ressources matérielles. Il est de votre responsabilité d'éliminer vos déchets d'équipements en les confiant à un centre de collecte approuvé par la directive DEEE afin qu'ils y soient recyclés. La collecte et le recyclage de vos équipements participera à la conservation des ressources naturelles et permettra de s'assurer que ces déchets soient recyclés de manière à protéger à la fois la santé des êtres humains et l'environnement.

Pour des informations plus spécifiques sur les endroits où vous pouvez emporter votre équipement pour recyclage, veuillez contacter le bureau local de votre ville/conseil municipal, votre service local de mise au rebut ou le point de vente où vous avez acheté votre produit.

Statement of WEEE Compliance

Wirepath Home Systems, LLC is committed to meeting all requirements of the Waste Electrical and Electronic Equipment (WEEE) directive (2012/19/EC). The WEEE directive requires the manufacturers of electrical and electronic equipment who sell in EU countries: (1) label their equipment to notify customers that it needs to be recycled, and (2) provide a way for their products to be appropriately disposed of or recycled at the end of their product lifespan. For collection or recycling of Wirepath Home Systems, LLC products, please contact your local Wirepath Home Systems, LLC representative or dealer.

Statement of Commitment to the Environment

Wirepath Home Systems, LLC, understands that a commitment to the environment is essential for a healthy life and sustainable growth for future generations. We are committed to supporting the environmental standards, laws, and directives that have been put in place by various communities and countries that deal with concerns for the environment. This commitment is represented by combining technological innovation with sound environmental business decisions.

Europe Compliance

Compliance of this equipment is confirmed by the following logo that is placed on the product ID label that is placed on the bottom of the equipment. The full text of the EU Declaration of Conformity (DoC) is available on the regulatory webpage.



Australia and New Zealand Compliance

Compliance of this equipment is confirmed by the following logo that is placed on the product ID label that is placed on the bottom of the equipment.



FRONT AND REAR PANEL DESCRIPTIONS

Front panel

EA-RSP-8D-100



EA-RSP-12D-100



EA-RSP-16D-100

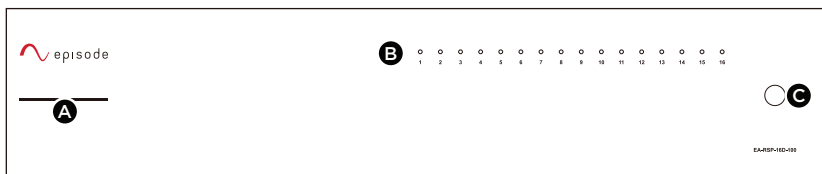

EA-RSP-2D-200

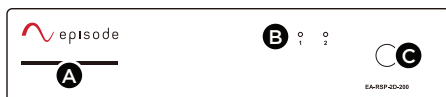

- A. Power LED light bar:** Blue LED light bar positioned on the left side of the front face panel. Blue LED is at its highest intensity on the left side of the light bar. LED functionality:
- Blue LED On = Amplifier is active or in Standby mode.
 - Blue LED Off = Amplifier power is off.
- B. Status LED:** Bi-color LED to show system status. The LEDs on the front panel indicate the amplifier's operating state. Each channel has one bi-color LED for each zone. LED functionality:
- Blue LED (solid): Amplifier is on and functioning properly.
 - Red LED (solid): Amplifier is on but is not functioning properly; check for possible short at speaker output.
 - LED off (when power LED is blue): Amplifier channel is off.
- C. Power button:**
- The Power button is enabled by default but can be disabled using the browser user interface.
 - Turn on the amplifier or put it into Standby mode with a press and release of the power button (momentary).
 - Put the amplifier into deep Standby mode (<0.5W) with a press and hold of the power button (about six seconds).

Back panel

EA-RSP-16D-100

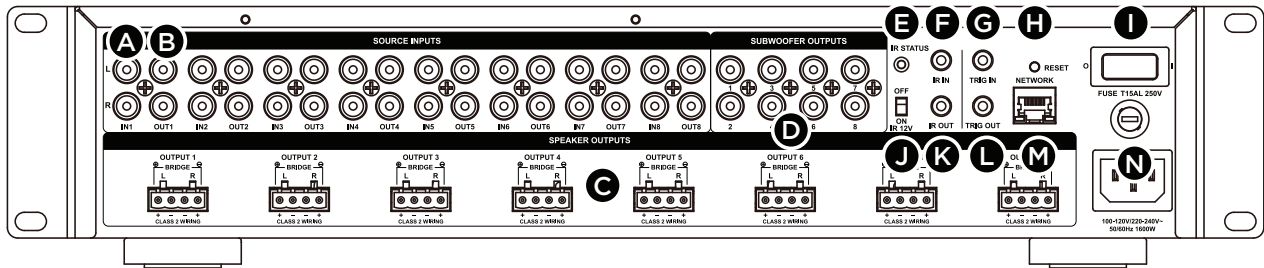

EA-RSP-2D-200

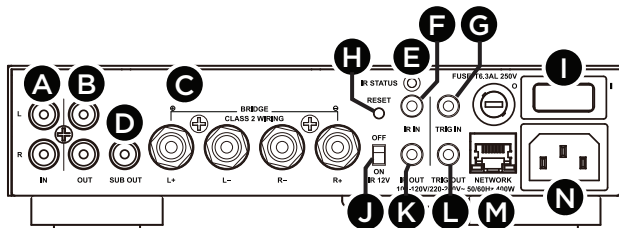

- A. Analog inputs:** Local line-level inputs, analog RCA unbalanced type.
- B. Analog loop outputs:** Stereo RCA input loop outputs, RCA unbalanced type.
- C. Zone SPEAKER OUTPUTS:** 4-position Phoenix-style connectors (8-, 12-, and 16-channel models) and 5-way binding posts (2-channel model) for speaker wiring connections.
- D. SUBWOOFER OUTPUTS:** Each zone of the amplifier has a subwoofer analog RCA unbalanced-type output. This output will be comprised of both a left and right channel summed together and includes a fixed low-pass filter, set at 200 Hz. **Note:** Low-pass filter settings from DSP presets will affect only the speaker outputs, not these outputs.
- E. IR STATUS:** LED illuminates when the IR signal is received.
- F. IR IN:** 3.5 mm stereo port. The adaptive IR input circuit supports 38 KHz carrier frequencies.
- G. TRIG IN:** 3.5 mm port, used to accept a voltage trigger (4.5V-12V) from an external device, to turn on the amplifier or put it into standby.
- H. RESET:** A recessed micro-controlled push button.
 - Quick momentary press = reboot
 - Hold RESET button for 5 seconds = Returns network settings to DHCP default
 - Hold RESET button for 10+ seconds = Return the device to its factory default configuration.
- I. Power switch**
- J. IR power ON/OFF:** If on, +12V DC is applied to the IR IN jack, providing power for an external IR receiver. **Note:** Do *not* turn on IR power if a direct connection to a control system is used.
- K. IR OUT:** 3.5 mm port, used for looping IR out to additional amplifiers or devices.
- L. TRIG OUT:** 3.5 mm port, used for looping voltage trigger out to additional amplifiers or devices.
- M. NETWORK:** Standard RJ45 connector with LED indicator. 10/100 Ethernet. Port remains active when amp is in Standby mode.
- N. Power connector:** Use the supplied power cord to connect power.

INSTALLING THE AMPLIFIER

The full-width amplifiers (8-, 12-, and 16-channel models) come with rack-mount ears and can be installed in a 2U rack space or on a shelf.

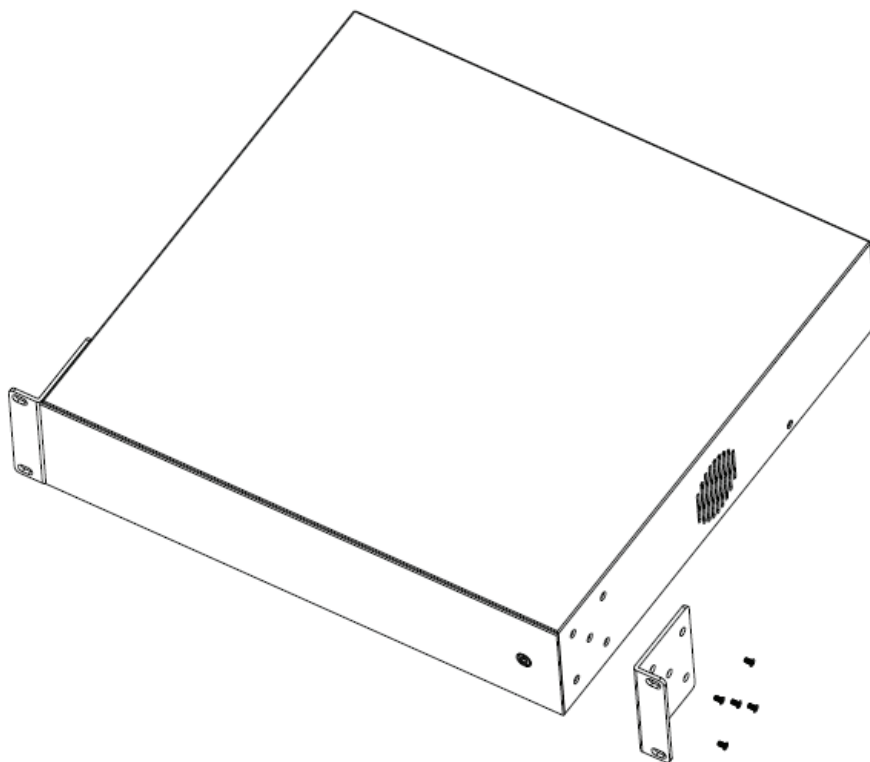

CAUTION! To prevent damage, maintain a 1U space below the amp for fresh air intake, and maintain adequate ventilation space to the sides of the amplifier. Do not place the amplifier directly on top of other components or cabinets unless the optional feet are affixed to the bottom. Do not place the side amplifier up against other components or cabinets. Doing either of these things will block ventilation openings.

ATTENTION ! Pour prévenir les dommages, toujours conserver un espace d'une unité en dessous de l'amplificateur. Éviter de placer l'amplificateur directement sur le dessus d'autres composants ou armoires sauf si le pied optionnel y est fixé en dessous. Éviter de positionner le côté de l'amplificateur contre d'autres composants ou armoires. Exécuter l'une des actions décrites ci-dessus bloquera les ouvertures de ventilation de l'appareil.

The two-channel amplifier comes with rack-mount ears and can be installed in a 1U rack space.

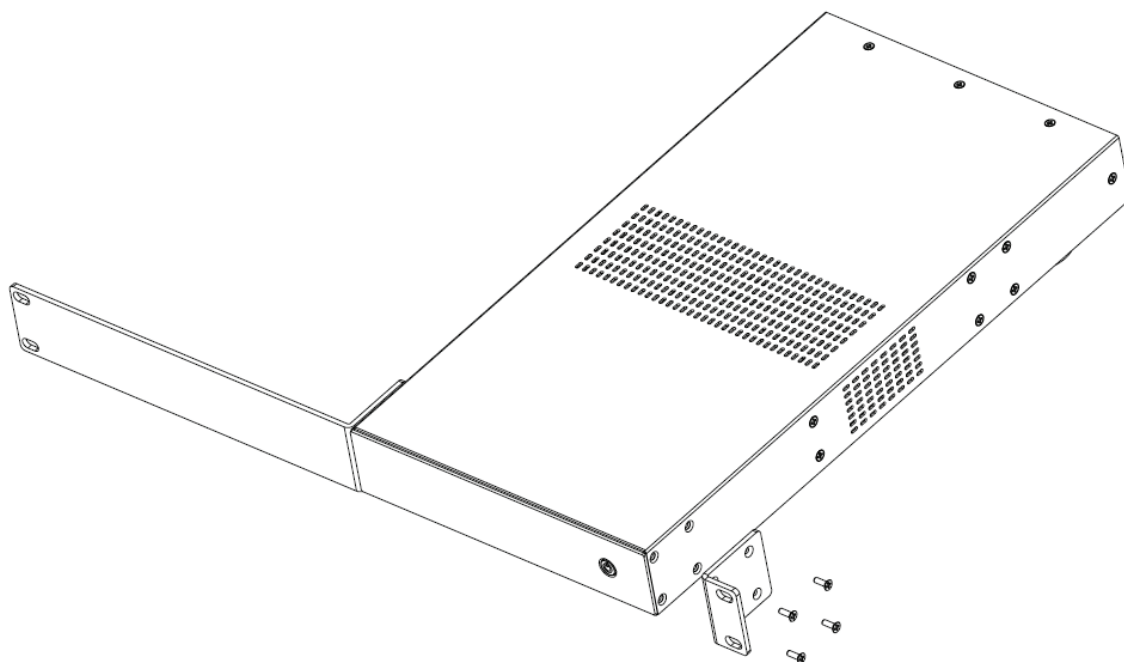

CONNECTING THE AMPLIFIER

These amplifiers are designed to operate as a multi-room audio system, requiring physical audio connections as well as connections to a control system. This section describes how to set up the physical connections required for the amplifier and the devices associated with it.

WARNING! Connecting speaker wires or input cables while the amplifier is powered may cause electrical shock and could damage the amplifier. Unplug the amplifier and the devices associated with it.

AVERTISSEMENT ! Les fils se reliant de haut-parleur ou les câbles entrés tandis que l'amplificateur est actionné, peuvent causer le choc et pourraient endommager l'amplificateur. Débranchez le cordon de secteur avant d'établir des rapports.

CONNECTING NETWORK AND POWER

To connect the amplifier to **ETHERNET** and **POWER** ports:

1. Connect an Ethernet Cat5E/6 cable from a local network

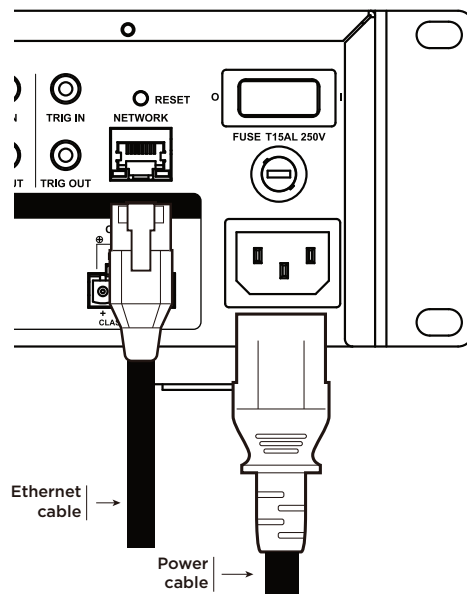

connection into the RJ45 port.

2. Connect the provided power cable to the amplifier's power input and to a power outlet.
3. When the power cable is connected, turn on the power switch. Initially, the amplifier turns on in Standby mode. Press the front-panel power button to fully power up.

CONNECTING AUDIO INPUTS

Source input jacks accept stereo line-level audio connections. Each source input can be routed to any speaker output.

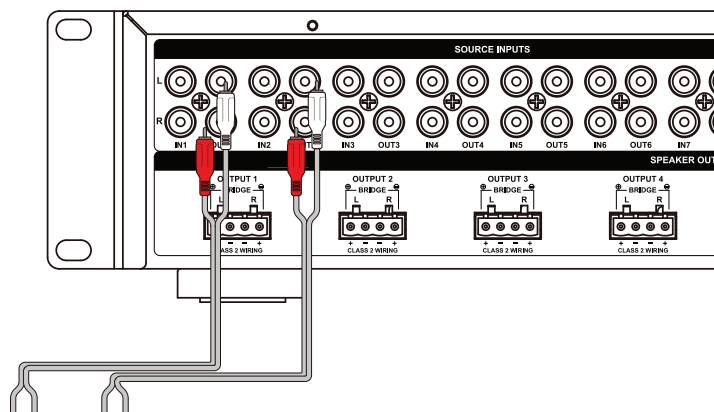

CONNECTING AUDIO OUTPUTS

Audio output jacks allow each source to be looped out to the audio inputs of an additional amplifier creating a larger audio system. A subwoofer output is joined with each speaker output, providing optional 2.1 audio for every audio zone.

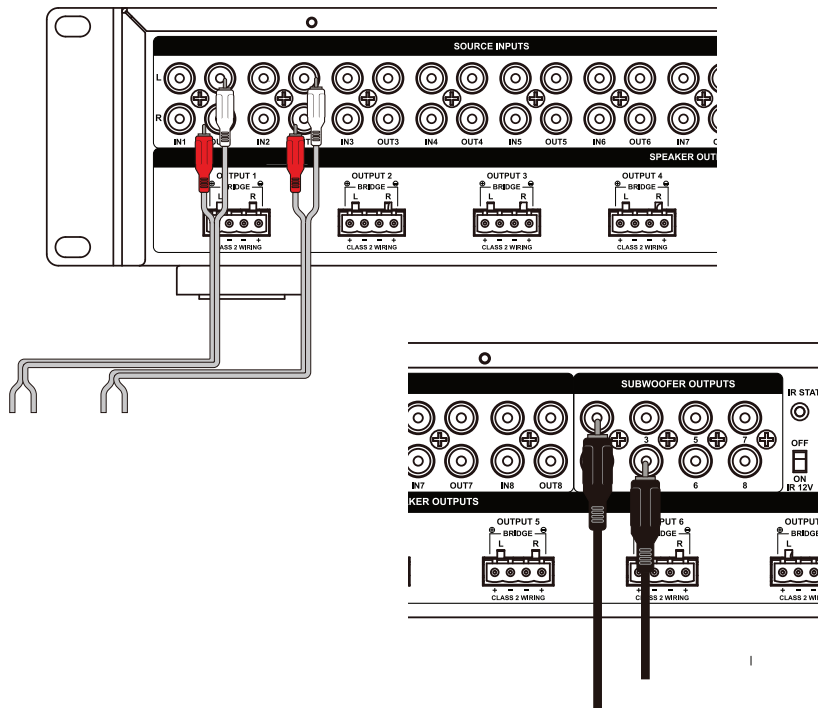

CONNECTING SPEAKERS

These amplifiers have Phoenix-style terminal blocks for speaker connections. Speakers can also be wired to bridge channels to increase the power available to the speakers.

CAUTION! Check the polarity of the speaker and wire before connecting to the amplifier.

ATTENTION ! Vérifiez la polarité des enceintes et des câbles avant de brancher à l'amplificateur.

To connect stereo speakers:

1. Power off the amplifier, then remove the output's terminal block.
2. Connect speaker wire to the terminal block and reinsert the terminal block into the amplifier.

IMPORTANT! The common signal of these speaker outputs must not be connected together or to any other common signal.

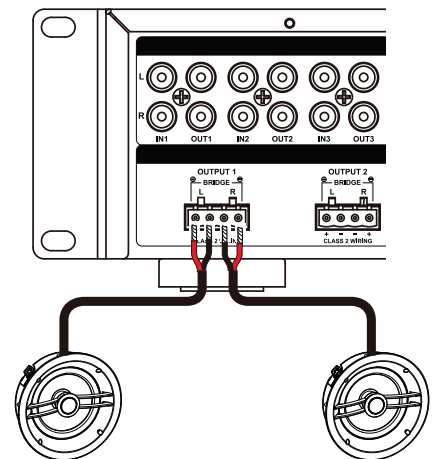

To connect bridged speakers:

1. Power off the amplifier, then remove the output's terminal block.
2. Connect the + terminal from the speaker to the + terminal of the left channel (L) on the amplifier.
3. Connect the - terminal from the speaker to the - terminal of the right channel (R) on the amplifier.

The two terminals for a bridged pair of speakers are marked by **+ BRIDGE -**.

In bridge mode, both amplifier channels output the same audio. A mono source can be connected to a bridge input to create a bridged mono output. Or, a stereo source can be connected to two bridge inputs (using two zones) to create a bridged stereo output.

4. Set the Bridge Mode **ON** through the browser user interface.

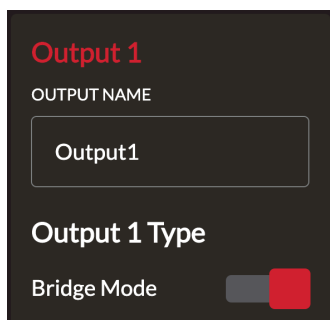
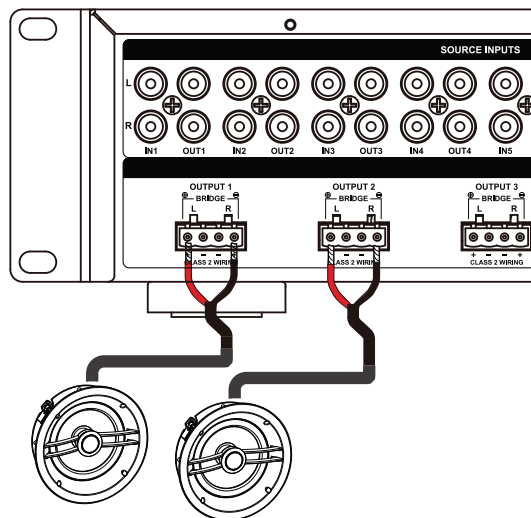

USING THE BROWSER USER INTERFACE

1. Connect an Ethernet Cat5E/6 cable from a local network connection into the RJ45 port on the amplifier.
2. Power on the amplifier.
3. In a web browser on the same local network, enter the amplifier's IP address that was assigned by the router (such as **192.168.1.2**). The login screen opens.
4. Enter the default (first-time only) password "**episode**" (the user name is also "**episode**"). The amplifier's configuration screen opens.

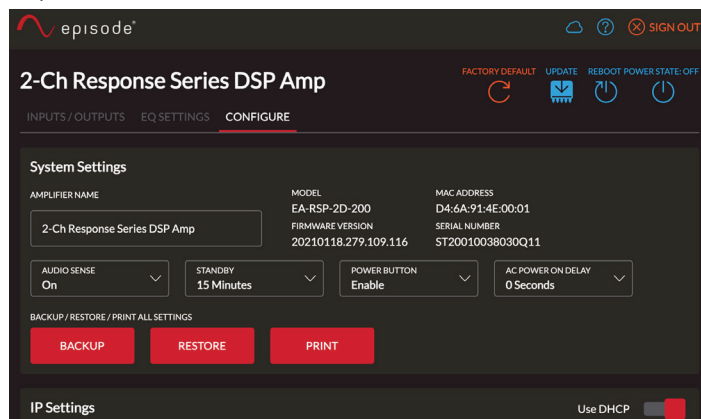

Note: The first time you access the interface, or after a reset to factory default settings, you must change the password.

5. Set the volume gain through level trim bar.

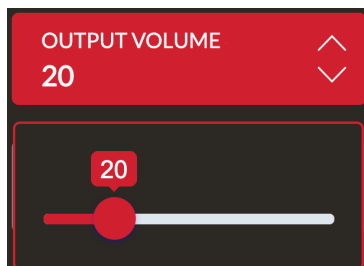

- Use Source selection to switch input sources corresponding to output channels.

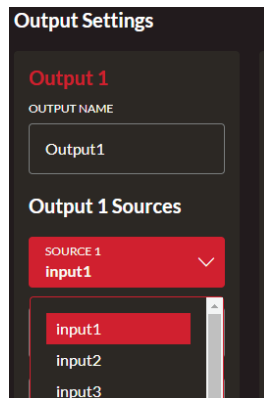

- Select preset equalizer settings in the **DSP PRESET** list.

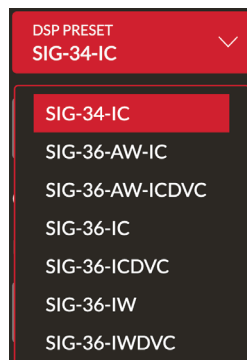

- Edit presets in the DSP PRESET EDIT menu, including frequency response, limiter, EQ crossover (high-pass & low-pass), and delay.



For in-depth information on DSP presets and the browser user interface, visit the Episode Response Series Amplifier product page on SnapAV.com and click the **Videos** tab.

SETTING UP AMPLIFIER POWER OPTIONS

Response Series DSP amplifiers can be powered on and off using IP or IR power commands, the front panel power button (enabled by default), audio sense (enabled by default), or with a connected voltage trigger. The front panel power button and audio sense can be disabled using the browser user interface.

Audio Sense

Audio Sense (on by default) is ideal for installations where no control system is used and the method to turn the amplifier on and off is with the presence or absence of audio. If a control system is used, we recommend to turn Audio Sense off, as the control system will issue on and off commands for the amplifier.

If Audio Sense is on, the amplifier automatically goes into standby mode when no audio is sensed for 15 minutes (default). However, standby time duration can be changed in the Standby field, explained below. If Audio Sense is off, the amplifier ignores the presense or absence of audio and turns off using other methods.

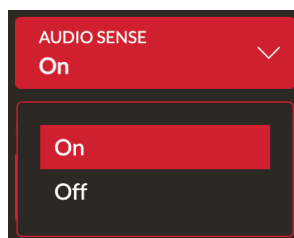

Standby

This setting determines the time it takes for the amplifier to go into Standby after no audio has been sensed. If Audio Sense is set to Off, this setting is hidden.

To set Standby:

1. Using the browser user interface, set **Audio Sense** to **On**.
2. Set **Standby** to one of five options: **5 minutes**, **15 minutes**, **30 minutes**, **1 hour**, or **3 hours**.

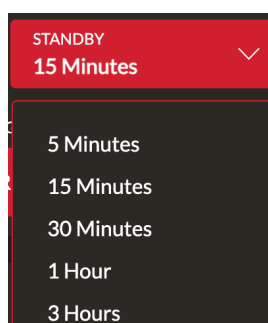

Note: The Standby wakeup time varies based on the selected power mode and amplifier model. See the Specifications section at the end of this guide for details.

Power Button

The Power Button setting (on by default) determines whether the amplifier can be turned on or off using the front panel power button.

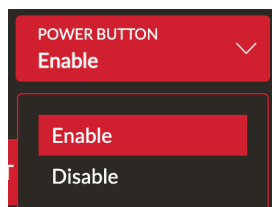

Voltage Trigger

Voltage Trigger control is typically ideal for installations where no control system is used and the desired method to turn the amplifier on and off is with the presence or absence of voltage.

When using Voltage Trigger, no changes need to be made within the browser user interface. When a voltage trigger cable is connected, only the presence or absence of voltage will turn the amplifier on or off. IP/IR power commands, audio sense, and the front panel power button will be ignored.

1. Connect the 4.5V-12V trigger cable from the trigger device to the **TRIG IN** port.

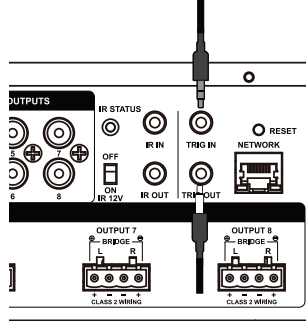

2. (Optional) Connect the **TRIG OUT** (12V DC) port to another amplifier to link their power controls.

SPECIFICATIONS

General

| Specification | EA-RSP-8D-100 | EA-RSP-12D-100 | EA-RSP-16D-100 | EA-RSP-2D-200 |
|----------------------------------|---|--|--|--|
| Analog inputs | Stereo RCA inputs | | | |
| | 4 pair | 6 pair | 8 pair | 1 pair |
| Analog loop outputs | Stereo RCA outputs | | | |
| | 4 pair | 6 pair | 8 pair | 1 pair |
| Speaker outputs | 8 channels: 4 stereo or bridged outputs | 12 channels: 6 stereo or bridged outputs | 16 channels: 8 stereo or bridged outputs | 2 channels: 1 stereo or bridged output |
| Trigger control | 1 x 3.5 mm (in, 4.5V-12V DC), 1 x 3.5 mm (out, 12V DC) | | | |
| Trigger voltage range (external) | 4.5V-12V DC | | | |
| IR control | 1 x 3.5 mm (in), 1 x 3.5 mm (out) | | | |
| IR power | +12V provides +12V DC to power an IR receiver unit, on/off selectable | | | |
| IR voltage range | 2V-12V | | | |

Audio specifications

| Specification | EA-RSP-8D-100 | EA-RSP-12D-100 | EA-RSP-16D-100 | EA-RSP-2D-200 |
|---|--|----------------|----------------|---|
| Frequency response | 20 Hz to 20 kHz, ± 2 dB at 1/8 power | | | |
| Subwoofer output frequency band | 20 Hz to 200 Hz, fixed - biquad low-pass filter at 200 Hz, 6 dB/octave slope | | | |
| Analog loop outputs | Output 2 Vrms at 10K ohm impedance load | | | |
| Power output @ 8 Ω , 2 channels driven | 2x50W 1 kHz | | | 2 x 100W 1 kHz |
| Power output @ 4 Ω , 2 channels driven | 2x100W 1 kHz | | | 2 x 200W 1 kHz |
| Power output @ 8 Ω , all channels driven | 8x50W 1 KHz | 12x50W 1 kHz | 16x50W 1 kHz | 2 x 100W 1 kHz |
| Power output @ 4 Ω , all channels driven | 8x100W 1 KHz | 12x85W 1 kHz | 16x80W 1 kHz | 2 x 200W 1 kHz |
| Power output bridged @ 8 Ω | 4x200W 1 KHz | 6x170W 1 kHz | 8x160W 1 kHz | 1 x 400W 1 kHz |
| Minimum impedance | 2 ohm | | | 1 ohm |
| Auto sensing sensitivity | 2.5 mVrms | | | |
| Input sensitivity | 1 Vrms | | | |
| Input impedance | RCA analog input: 20k Ω | | | RCA analog input: 22k Ω |
| Input gain control | Compensate for wide range of sources input levels from 0.5 Vrms to 4 Vrms | | | |
| Total harmonic distortion @1W, 1 kHz | <0.05% | | | |
| Total harmonic distortion @50W, 1 kHz | 1% | | | 1% @ 100W |
| Signal-to-noise ratio | >95 dB A-weighted @ rated power | | | |
| Frequency response | 20 Hz - 20 kHz ± 2 dB | | | |
| Crosstalk | < -60 dB @ all channels | | | |
| Dynamic range: S/N ratio | > 100 dB A-weighted @ rated power | | | |
| THD | 0.01% 1 kHz @1/8 rated power 4 Ω or 8 Ω | | | 0.01% 1 kHz @1/8 rated power 4 Ω or 8 Ω |

Power

| Specification | EA-RSP-8D-100 | EA-RSP-12D-100 | EA-RSP-16D-100 | EA-RSP-2D-200 |
|---|--|------------------|------------------|-----------------|
| AC mains power | 100-120V / 200-240V, 50/60 Hz | | | |
| Power consumption | 800W | 1200W | 1600W | 200W |
| Standby power consumption | When Power Button is enabled: 1.4W with network connection, < 0.5W with no network connection When Audio Sense or Voltage Trigger is enabled: 4W | | | |
| Standby wakeup time (Power Button) | Up to 9 seconds | Up to 10 seconds | Up to 11 seconds | Up to 4 seconds |
| Standby wakeup time (Voltage Trigger / Audio Sense) | 4 seconds (all models) | | | |
| Fuse rating | 10A/250V | 15A/250V | | 6.3A/250V |
| Power connection | NEMA 5/15P 3 prong to IEC 60320 C13, 1.8m length | | | |

Thermal

| Specification | EA-RSP-8D-100 | EA-RSP-12D-100 | EA-RSP-16D-100 | EA-RSP-2D-200 |
|-----------------------|--|----------------|----------------|---------------------------|
| Operation temperature | -10 to +50 °C (+14 to +122 °F) (indoor) | | | |
| Storage temperature | -30 to +70 °C (-22 to +158 °F) | | | |
| Relative humidity | 20-90% RH | | | |
| Cooling method | Two fans mounted, 1 each in left and right sides | | | Fanless (passive) cooling |

Miscellaneous

| Specification | EA-RSP-8D-100 | EA-RSP-12D-100 | EA-RSP-16D-100 | EA-RSP-2D-200 |
|----------------------------------|--|---------------------|-------------------|--|
| Front power LED | Blue LED light bar | | | |
| System status LED | Bi-color LED (8) | Bi-color LED (12) | Bi-color LED (16) | Bi-color LED (2) |
| Ethernet | 1 x RJ45 with LED | | | |
| Factory restore button | Yes | | | |
| Dimensions (H x W x D) | 483 x 424 x 89 mm (19.0 x 16.7 x 3.5 in.) | | | 420 x 211 x 44.5 mm (16.5 x 8.3 x 1.8 in.) |
| Dimensions with feet (H x W x D) | 483 x 424 x 101 mm (19.0 x 16.7 x 4.0 in.) | | | 420 x 211 x 56 mm (16.5 x 8.3 x 2.2 in.) |
| Weight | 8.5 kg (18.7 lb.) | 9 kg (19.8 lb.) | 9.5 kg (20.9 lb.) | 3.6 kg (7.93 lb) |
| Shipping weight | 24.0 kg (52.91 lb.) | 25.0 kg (55.12 lb.) | 26.0 (57.32 lb.) | 16.61 kg (25.58 lb) |
| Regulatory certifications | UL, CE, FCC | | | |
| Topology | Class D | | | |

WARRANTY

Warranty and legal notices

Find details of the product's Limited Warranty at snapav.com/warranty or request a paper copy from Customer Service at 866.424.4489. Find other legal resources, such as regulatory notices and patent information, at snapav.com/legal.

TROUBLESHOOTING

If you have questions about your new amplifier, contact Customer Service at:

(866) 838-5052

techsupport@snapav.com

snapav.com



© 2021 Wirepath Home Systems, LLC
200-00692-F Rev 21-04-15